

Features & Benefits

- Constant current design
- Patent pending dimmable design
- Over-current, over-voltage and short circuit protection
- Includes mounting holes for mechanical attachment and pre-wired leads
- Compact design is easily configured into existing and new luminaires
- Can be used to meet the requirements of CA Title 24, ENERGY STAR® and other green initiatives



Required Brillia LED Modules

BB09 BD Series See Brillia LED module specifications

Ratings and Performance Specifications

Nominal AC Power Consumption @ 120VAC	10-12W
Nominal Input Voltage	120VAC
Nominal Power Factor	>0.7
Maximum Operating Range Ambient Temperature (Ta)	-40 to +50°C
Maximum Driver Case Temperature (@ designated temperature measurement point, TMP)	+80°C
Maximum Weight	96 grams
Safety/Compliance	
UL Class 2 Recognized Component E256806	
RoHs Compliant	
Output operating frequency ≥ 120Hz	
Meets FCC requirements for consumer use	
Class A sound rating	
Complies with IEEE C.62.41-1991, Class A operation	

Application Notes

1. The proper LED Driver Case Temperature at the designated temperature measurement point (TMP) is critical to ensure proper performance and long life. Careful design consideration required for factors such as ambient conditions (for example weather and surrounding atmosphere inside exterior luminaires) and proximity to other heat sources such as LED modules and other heat generating LED devices.
2. Abnormal operating conditions such as high humidity or elevated operating temperatures can be expected to negatively impact lumen output, product lifetime, or product performance.
3. Patent pending AC dimming works with most 3-wire electronic dimmers such as Lutron® Diva and Maestro, see www.BrilliaLED.com for application notes, wiring diagrams and other compatible dimmers. For technical support or application assistance, please contact Brillia.



Physical Dimensions

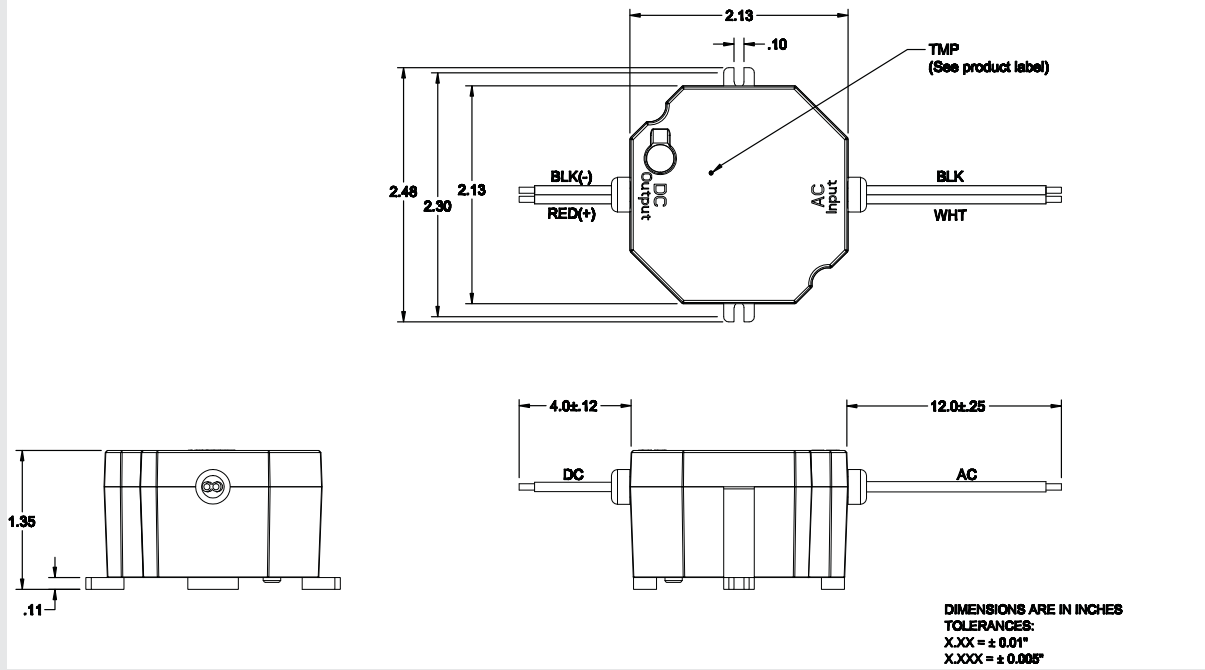

Part Number	Nominal Input Voltage (VAC)	Nominal DC Current (mA DC)	Sample Values Efficiency (%) at Max Load)	Max Output Power (W)	Nominal Input Voltage Dimmable ^[1]
BL26-DIM-30H	120	300mA	85%	10	Yes
BL26-DIM-34H	120	340mA	85%	12	Yes

^[1]Utilizing 3-wire electronic dimmer, see www.BrilliaLED.com for compatible dimmers.

Options

No additional options available.....for questions, please email sales@brillialed.com

Packaging

Drivers are labeled with SKU and lot traceability information and shipped in packaging designed to protect the drivers from damage during transit.

Warranty

3-Year limited warranty in accordance with Brillia published warranty. Product must be used with compatible Brillia components (modules, drivers, engines and/or accessories) and no maximum ratings (such as TMP) shall be exceeded during any expected operating conditions of the system.

Additional Information

